

Spindle Bearing B7218-E-T-P4S-UL

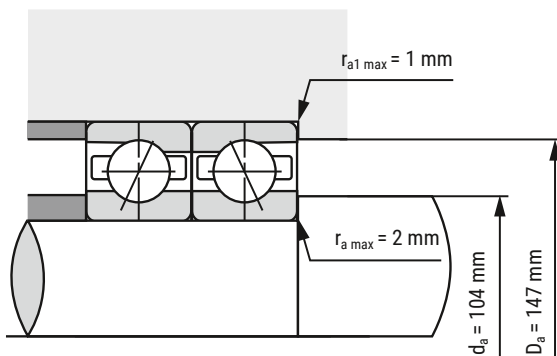
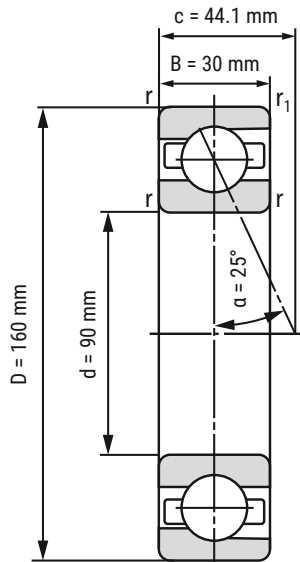

d	90 mm
D	160 mm
B	30 mm

c	44.1 mm	
D_a	147 mm	Tolerance: H12
d_a	104 mm	Tolerance: h12
r_{min}	2 mm	
r_{1 min}	1 mm	
r_{a max}	2 mm	
r_{a1 max}	1 mm	
α	25°	Contact angle

m	2.2 kg	Mass
C_r	116900 N	Basic dynamic load rating, radial
C_{0r}	99900 N	Basic static load rating, radial
F_{VL}	1270 N	Preload force
F_{VM}	2940 N	Preload force
F_{VH}	5880 N	Preload force
C_{aL}	280 N/μm	Axial rigidity
C_{aM}	382.4 N/μm	Axial rigidity
C_{aH}	501.7 N/μm	Axial rigidity
n_{G Grease}	7500 r/min	Limiting speed grease lubrication
n_{G Oil}	12000 r/min	Limiting speed oil lubrication

i All indications were made carefully and verified. Kugellager-Express doesn't assume any liability for incomplete or false indications.

HERE YOU'LL FIND THE
ITEM WEBPAGE
(click or scan)

